

19 RURAL ZONE RULES

Activities Tables

Policies 3.4.1, 5.4.1, 5.4.2, 5.4.3, 5.4.9, 5.4.10, 9.4.4, 9.4.5, 9.4.10, 14.4.6, 16.4.7

19.1 Subdivision Activities	
Subdivision excluding unit title subdivision	
Subdivision which complies with the standards in rules 19.5 and 19.8 unless specified below	C
Subdivision which does not comply with the standards specified in rule 19.5	D
Subdivision which complies with the standards of rule 19.5 but not rule 19.8	RD
Subdivision around any existing lawfully established dwelling which does not result in the creation of any new undeveloped site that contains no dwelling Note: this form of subdivision does not need to comply with the minimum net site area requirements of rule 19.5, but does need to comply with the access standards of rule 19.8	C
Subdivision around any existing lawfully established dwelling which does not result in the creation of any new undeveloped site that contains no dwelling, that does not comply with the access standards of rule 19.8	RD
Subdivision of land for utilities, reserves or conservation purposes	C
Subdivision of a site identified in Schedules 26.8 or 27.7	D
Subdivision in the Blue Mountains Area	NC
Creation of a lot that does not have formed legal access to a formed legal road, unless the proposal is for a paper road or other access to be formed as a condition of subdivision approval in accordance with the Code of Practice for Civil Engineering Works	NC
Subdivision which creates building platforms within 32m of high voltage (110kV or greater) electricity transmission lines as shown on the Planning Maps *(refer to the definition of <i>transmission line</i>)	RD
Subdivision of a site within the Pinehaven Catchment Overlay	
Subdivision of a site within the Pinehaven Catchment Overlay	RD
Subdivision of a site within the Pinehaven Catchment Overlay that does not meet the standard of 19.27a	NC
Subdivision in the Mangaroa Flood Hazard Extent	
Subdivision within the Ponding Area and Erosion Hazard Area of the Mangaroa Flood Hazard Extent, which results in any undeveloped lots that contain no dwelling or non-residential building.	RD

<p>Subdivision within the Ponding Area and Erosion Hazard Area of the Mangaroa Flood Hazard Extent which results in any undeveloped lots that contain no dwelling or non-residential building, where one or more of the following occurs:</p> <ul style="list-style-type: none"> • the proposed access is below the 1 in 100-year flood level; • proposed access is located within an overflow path; • proposed lots do not comply with standard 19.5. 	D
<p>Subdivision within the Mangaroa Flood Hazard Extent which results in any new undeveloped lots that contain no dwelling, where one or more of the following occurs:</p> <ul style="list-style-type: none"> • the proposed building platform is located within an overflow path or river corridor; • access to the building platform is within a river corridor 	NC
Updates of existing company lease and cross lease, and all unit title subdivision	
<p>Subdivision which is a unit title subdivision or an alteration to a company lease, unit title or cross lease title to include a building extension or alteration or accessory building on the site (excluding an additional dwelling) that has been lawfully established in terms of the Building Act 2004</p>	C

Key	P	Permitted activity which complies with standards for permitted activities specified in the Plan
	C	Controlled activity which complies with standards for controlled activities specified in the Plan
	RD	Restricted discretionary activity
	D	Discretionary activity
	NC	Non complying activity

19.2	Land Use Activities	Rural Lifestyle	Rural Valley Floor	Rural Hill
	Rural Activities			
	Farming activities (unless otherwise specified in this table)	P	P	P
	Intensive animal farming, including pig farming	NC	D	D
	Forestry	P	P	P
	Topsoil removal	D	D	D
	Field based agricultural research and ancillary buildings and activities (including field days and open days) on the Kaitoke Agricultural Research Farm legally described as Pt DP 12431 Lot 2 DP 22844 & sec 41 Pt secs 1, 2, 29 Pakuratahi Dist Blk XV Akatarawa SD - Animal Research Farm Sec 1 SO 24123 Sec 43 SO 23658 - Animal Research Station, Sec 3 Pakuratahi Dist Blk XV Akatarawa SD.	-	P	-
	Residential Activities			
	One dwelling per site	P	P	P
	One family flat in conjunction with a dwelling	P	P	P
	Family flat which does not meet permitted or controlled activity standards	RD	RD	RD
	Two or more dwellings on any one site	NC	NC	NC
	Other Activities			
	Home occupations incidental to residential activities carried out on the site	P	P	P
	Home occupations, ancillary to residential activities carried out on the site, which do not meet permitted or controlled activity standards	RD	RD	RD
	Visitor accommodation, other than as part of any home occupation	D	D	D
	Veterinary clinics	D	P	P
	Educational institutions and places of assembly	D	D	D
	Community facilities	D	D	D
	Tourism facilities	D	D	D

Land Use Activities	Rural Lifestyle	Rural Valley Floor	Rural Hill
Passive recreation activities	P	P	P
Active recreation activities	D	C	C
Signs	P	P	P
Signs which do not comply with permitted activity standards	RD	RD	RD
Removal of a building from a site	P	P	P
Establishment of a relocated building from another site	C	C	C
Buildings accessory to a permitted or controlled activity which do not comply with permitted or controlled activity standards	RD	RD	RD
Gang fortifications	Prohibited		
Buildings or structures within 12m of high voltage (110kV or greater) electricity transmission lines as shown on the Planning Maps *(refer to the definition of <i>transmission line</i>)	NC	NC	NC
Buildings or structures within 12-32m of high voltage (110kV or greater) electricity transmission lines as shown on the Planning Maps *(refer to the definition of <i>transmission line</i>)	RD	RD	RD
Activities listed as permitted or controlled which do not comply with the relevant standards in this chapter, except as specified below	D	D	D
Activities listed as permitted or controlled which do not comply with the access standards in 19.8	RD	RD	RD
Activities which are not listed in this Table unless otherwise covered in the City-wide provisions of the Plan	NC	NC	NC

19.3 City-wide provisions

Each activity including subdivision in the Rural Zone shall comply with the relevant permitted activity standards in the City-wide provisions of the Plan as listed below.

Chapter	City-wide provisions
23	Earthworks
24	Esplanade Reserves and Strips
25	Reserves and Leisure Facilities Contributions
25A	Temporary Events
26	Heritage Features

Chapter	City-wide provisions
27	Notable Trees
27A	Urban Tree Groups and Removal of Indigenous Vegetation
28	Southern Hills Overlay Area and Protected Ridgelines
29	Water Bodies
30	Utilities
31	Car Parking
32	Noise and Vibration
33	Flooding and Fault Band Hazards
34	Hazardous Substances and Contaminated Land

19.4 Controlled activities – restrictions on notification

Subject to sections 95A(2)(b), 95A(2)(c), 95A(4) and 95C of the Act, a resource consent application for a controlled activity is precluded from public notification under section 95A and, subject to section 95B(3), is precluded from limited notification under section 95B(2) of the Act.

Standards for Permitted and Controlled Activities

19.5 Minimum requirements for subdivision

Policies 3.4.1, 5.4.1, 5.4.9

Zone	Minimum net site area	Shape factor
Rural Lifestyle	1ha	50m
Rural Valley Floor	4ha	N/A
Rural Hill	20ha	N/A
Exemptions		
These standards shall not apply to any lot for utility, reserve or conservation purposes.		

19.6 Subdivision which complies with the standards in rule 19.5 and 19.8, and subdivision of land for utilities, reserves or conservation purposes

Policies 5.4.12, 9.4.3, 10.4.1

Council may impose conditions over the following matters:

- Design, appearance and layout of the subdivision.

- Landscaping.
- Provision of and effects on utilities and/or services.
- Standard, construction and layout of vehicular access.
- Earthworks.
- Provision of esplanade reserves and strips.
- Protection of any special amenity feature.
- Financial contributions.

19.7 Subdivision which is a company lease, cross lease or unit title subdivision

Policies 9.4.3, 10.4.1

In addition to the matters listed in rule 19.6, Council may impose conditions over the following matters:

- Allocation of accessory units to principal units and covenant areas to leased areas to ensure compliance with car park provisions and to ensure practical physical access to units.
- Allocation of areas.

19.8 Access standards for subdivision and land use activities

Policies 5.4.6, 9.4.3

- Access to any allotment, including rear lots, shall be sited at least 20m, measured along the road carriageway, from any access on an adjoining lot, unless the two access provisions join the road carriageway at a common point.
- All accessways and manoeuvring areas shall be formed and surfaced in accordance with the Code of Practice for Civil Engineering Works. Exemption – the requirement for accessways serving sites solely occupied by unstaffed utilities shall be that the accessway shall be surfaced with permanent all weather surfacing for a minimum length of 5m from the edge of the road carriageway seal.
- All sites shall have practical vehicle access to car parking and loading spaces, in accordance with the Code of Practice for Civil Engineering Works. This requirement does not apply to sites solely occupied by unstaffed utilities, provided that vehicles associated with utilities shall not obstruct the footpath or create a traffic hazard on the road.
- Vehicular access to a corner lot shall be located no closer than 8m from the street corner. Where a site is located on an intersection of a primary or secondary arterial route (identified in Chapter 37), the siting of the vehicular access shall be located as far as practicable from the corner of the street. The 8 metre setback shall be measured from where the two front boundaries of the site (refer to the definition of a corner lot) join, or in accordance with the diagram below.

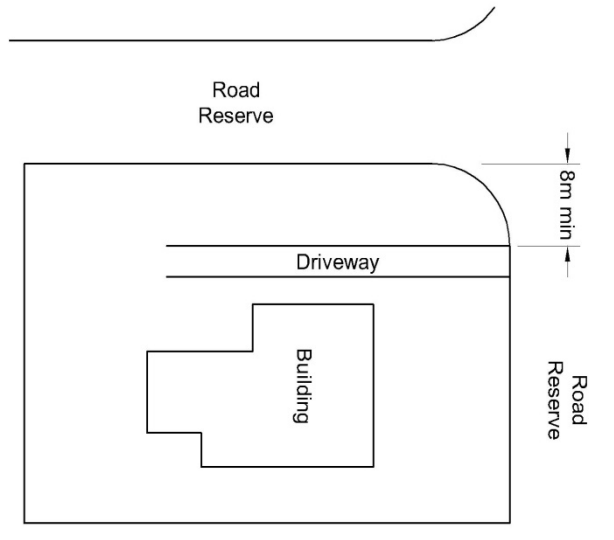

- Where a corner site is located at an intersection of a national, primary or secondary arterial traffic route, as identified in Chapter 37, no building, fence or other structure is to be erected and no vegetation allowed to grow so as to obstruct a traffic sight line.
- At the intersection of a road or rail level crossing, no building, fence or other obstructions which block sight lines for trains shall be erected, placed or grown in the hatched area marked in Diagram A in Chapter 38.
- Subdivision and land use activities with direct access to a State Highway shall comply with the access and visibility standards set out in Diagrams B to E in Chapter 38.

19.9

Setbacks

*Policies 5.4.1,
5.4.11*

The setback distance for buildings from boundaries shall not be less than:

Rural Hill Sub-zone - all boundaries:	12m
Rural Valley Floor Sub-zone - all boundaries:	12m
Rural Lifestyle Sub-zone - front boundary:	8m
Rural Lifestyle Sub-zone - all other boundaries:	3m

Notes:

- Sites of less than 1500m² in all Rural Sub-zones shall comply with the setback standards of the Residential Conservation Sub-zone.
- New dwellings shall not be built within 10m of an existing forest.

Exemptions:

- Eaves, bay windows or similar features, may encroach into boundary setbacks by up to 0.7m.
- Non-enclosed and uncovered decks of 1.0m or less in height above ground level.

19.10

Building height

*Policies 5.4.1,
5.4.11, 5.4.12*

The maximum height of any building shall not exceed 8m.

Exemption:

Chimneys, flues and minor decorative features may exceed the maximum height by up to 1m.

19.11

Sunlight Access

*Policies 4.4.4,
5.4.11, 5.4.12*

Height control planes apply to all buildings:

- Adjacent to a Residential Zone.
- On sites smaller than 1500m² in a Rural Zone.

Buildings shall be designed so that they fit within the height control planes defined below:

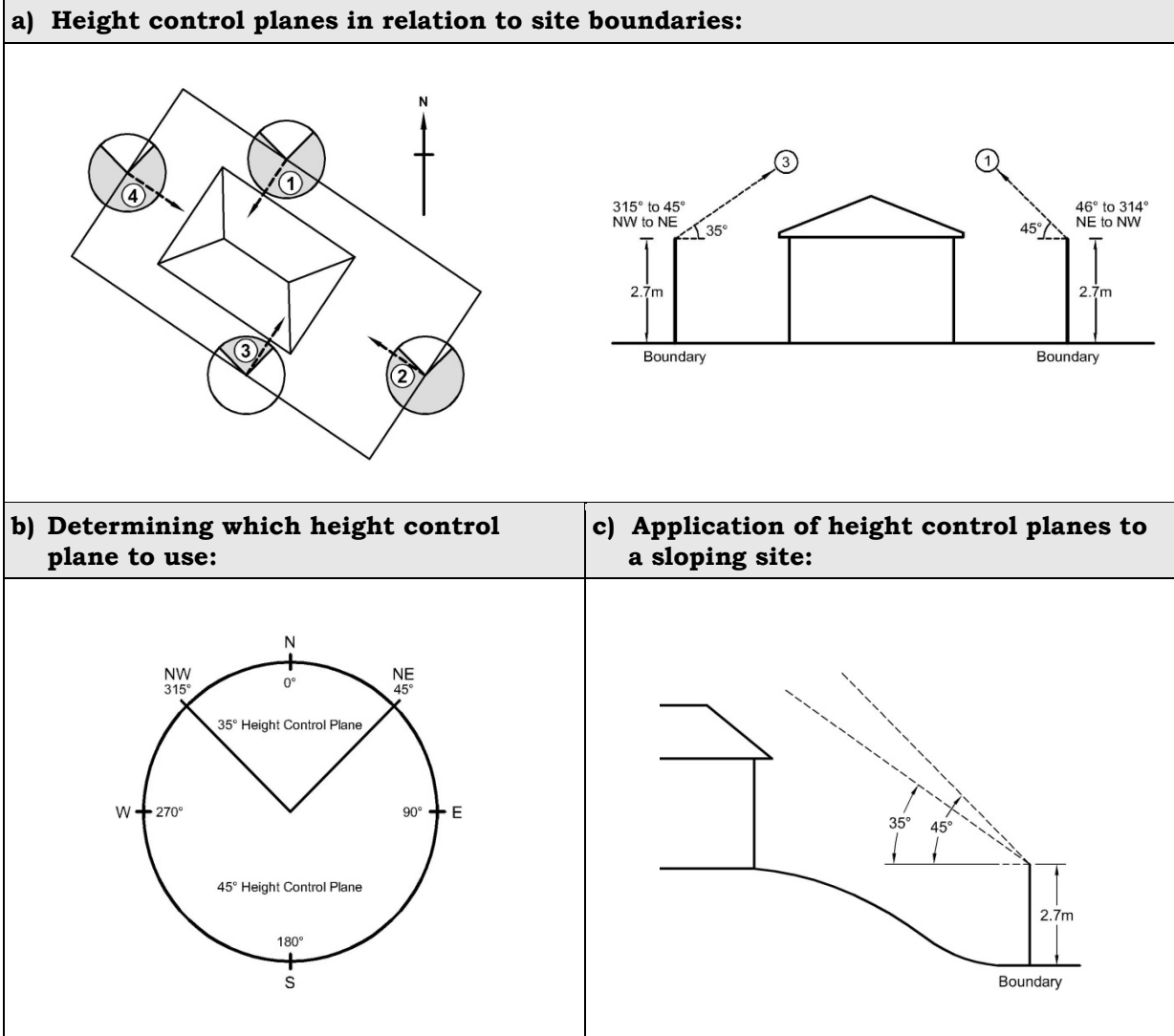

Exemptions:

- Chimneys, flues, and minor decorative features may extend beyond the height control plane by up to 1m.
- The top of a dormer or gable, but not the eaves, may extend beyond the height control plane by up to 0.5 m provided that the aggregate length of all projections through the plane does not exceed 25% of the total building length.
- Where the boundary involved in the measurement of the height control plane adjoins an access strip or right-of-way to a rear lot, the outside boundary of such an access strip or right-of-way may be substituted for the nearest site boundary.

19.12

Water supply, stormwater and wastewater

*Policies 9.4.3,
13.4.1*

All activities shall comply with the water supply, stormwater and wastewater standards in the Code of Practice for Civil Engineering Works.

19.13**Artificial light**

*Policies 5.4.1,
15.4.1*

- Light emissions from a site shall not exceed a measurement of 8 lux (lumens per m²) measured 1.5m above the ground at the boundary in both horizontal and vertical planes.
- Light emissions from a site shall not spill directly onto roads.
- Light emissions shall be measured by an instrument that meets NZSS CP22 (1962) requirements and amendments.

19.14**Forestry**

*Policies 5.4.2, 5.4.4,
5.4.7, 5.4.8, 5.4.11*

- a) Forest owners and managers are expected to comply with the management and operational practices in the New Zealand Forest Code of Practice.
- b) There shall be a 10m non-millable buffer from any water body with a width greater than 1m.
- c) A buffer width of at least 10m is to be provided to any existing dwelling on another site.
- d) No less than 20 working days before harvesting any forest or section of a forest, the harvester shall submit a Forestry Harvesting Notice to the Council. This Notice shall contain the following information:
 - A description of the extent of the area to be harvested and the method of tree removal from the site.
 - The date of commencement and duration of the harvesting.
 - The expected volume of timber to be extracted.
 - The regularity of logging truck movements.
 - The roads proposed to be used for the cartage of timber or logs or machinery used in harvesting.
 - Appropriate measures to manage the adverse impacts of road use resulting from harvesting.

19.15**Home occupations ancillary to residential activities carried out on the site**

*Policies 5.4.11,
15.4.1*

- At least one of the persons engaged in the home occupation shall live on the site as their principal place of residence.
- No more than three non-resident persons may be engaged in the home occupation at any one time.
- The repair or maintenance of vehicles or engines, other than those belonging to the residents, is not permitted.
- The site shall not be used as a depot for any heavy vehicle associated with a trade.

- Only goods produced or grown on the site may be sold from the site, provided that no retailing activity shall take place where access is to the State Highway.
- Homestay activities, where accommodation and meals are provided in a family type environment, are permitted provided the total number of persons accommodated on the site at any one time, including persons normally resident on the site, does not exceed twelve.
- Equipment used shall not interfere with radio and television reception.

19.16

Active recreation

Policy 5.4.11

Council may impose conditions on:

- Avoiding, remedying or mitigating adverse effects of the use on the locality.
- Traffic generation, car parking, access arrangements and on-site vehicle movements.
- Bulk, location, design and appearance of buildings.
- Hours of operation.
- Signage.
- Landscaping and screening.
- Servicing and infrastructure.
- Mitigation of noise effects.
- Financial contributions.

19.17

Temporary signs

*Policies 15.4.5,
16.4.4*

Temporary signs, in all zones, must meet all of the following conditions:

- The sign face shall be no greater than 3m² in area visible from any one direction.
- The sign shall relate to a temporary or one-off activity.
- The maximum period for any temporary sign shall be 2 months, except for signs required to be erected for health and safety reasons, where the maximum period shall be 6 months.
- Any temporary sign shall be removed within 48 hours of the ceasing of the activity to which the sign relates.
- Real estate signs involved in the advertising and sale of properties must relate to the property on which they are erected.
- Any sign shall be located so that it does not obstruct any official traffic sign

- Any sign must not be flashing, animated or continuously differ in form or detail.
- Any sign directed at the State Highway where the speed limit is 70km/hr or greater shall comply with the following:
 - Have a minimum letter height of 160mm; and,
 - Contain no more than six words and symbols and no more than 40 characters; and,
 - Be located so as to provide an unrestricted view to the motorist for a minimum distance of 180 metres.

19.18 Signs within roads

*Policies 15.4.5,
16.4.4*

Road, traffic and advertising signs within roads, in all zones, must be approved by the road controlling authority.

19.19 All other signs

*Policies 15.4.5,
16.4.4*

- One free-standing sign or painted wall or roof sign per site with a maximum face area of 3m² visible from any one direction.
- No part of a free-standing sign shall be more than 3.0m above ground level.
- Any sign shall be situated on the site to which the sign relates.
- Any sign which is located within 50m of, and visible from a Residential Zone or directed at the State Highway must not be flashing, animated or continuously differ in form or detail.
- Any sign shall be removed when the activity to which it relates has ceased.
- Any sign shall be located so that it does not obstruct any official traffic sign.
- Any sign directed at the State Highway where the speed limit is 70km/hr or greater shall comply with the following:
 - Have a minimum letter height of 160mm; and,
 - Contain no more than six words and symbols and no more than 40 characters; and,
 - Be located so as to provide an unrestricted view to the motorist for a minimum distance of 180 metres.

19.20 Relocated Buildings

Policy 5.4.12

Council may impose conditions on:

- a) Reinstatement works to the condition and appearance of the building relating to:

- Works to the exterior fabric of the building to repair, replace or renovate damaged, defective or substandard elements;
 - Painting and/or cleaning of the exterior fabric of the building if necessary;
 - Cladding or other means of enclosing open subfloor areas below the building;
 - Alterations required to ensure that the reinstated exterior of any relocated building is not likely to detract from the amenity values of the surrounding area.
- b) The timeframe for the work to be completed;
- c) Landscaping, screening and boundary treatment;
- d) Execution of a performance bond to provide security for exterior reinstatement works required as a condition of resource consent.
- e) Provision of and effects on utilities and/or services.
- f) Standard, construction and layout of vehicular access.

Notes in respect of d):

- A bond is not mandatory. It will only be required when Council considers it necessary in view of the scale and/or nature of exterior reinstatement works required. The requirement for a bond and its value will be determined in the context of the building assessment report submitted at resource consent stage.
- The bond shall be executed at the time application is made for a building consent, and security shall be in the form of either money or a guarantee by an institution approved by Council as guarantor.
- The bond shall be cancelled upon completion of exterior reinstatement works required in the conditions of the resource consent. The verification method for completion of these works shall be the issuing of a full or interim Code Compliance Certificate as defined in the Building Act. In the event that conditions relating to exterior reinstatement works are not complied with, the bond may be used in whole or in part to complete the works.

Restricted Discretionary Activities

19.21 Subdivision which creates building platforms within 32m of high voltage (110kV or greater) electricity transmission lines as shown on the Planning Maps

Policies 16.4.1, 16.4.7

In addition to the matters listed in rule 19.6, Council will restrict its discretion to, and may impose conditions on:

- The extent to which the subdivision design manages potential conflicts with existing lines by locating roads and reserves under the route of the line.
- The extent to which maintenance and inspections of transmission lines are affected including access.
- The extent to which potential adverse effects including risk or injury, property damage and visual impact are mitigated through the location of building platforms and landscaping.
- The outcome of any consultation with the affected utility operator.
- Separation distances between trees and conductors and the location and mature size of trees planted near the transmission lines.
- Compliance with the New Zealand Electrical Code of Practice for Electrical Safe Distances 2001 (NZECP 34:2001).
- Measures necessary to avoid, remedy or mitigate the potential adverse effects of earthworks, dust generation and construction activities, including provision of appropriate separation distances, managing the risks to structural integrity, and safety risks associated with the use of mobile machinery.

Restriction of notification

Subject to sections 95A(2)(b), 95A(2)(c), 95A(4) and 95C of the Act, a resource consent application under this rule will be precluded from public notification under section 95A, and limited notification will be served on Transpower New Zealand Limited as the only affected party under section 95B.

19.22 Buildings or structures within 12-32m of high voltage (110kV or greater) electricity transmission lines as shown on the Planning Maps

Policy 16.4.7

Council will restrict its discretion to, and may impose conditions on:

- a) Compliance with the New Zealand Electrical Code of Practice for Electrical Safe Distances 2001 (NZECP 34:2001).
- b) The location, height, scale, orientation and use of buildings and structures to ensure the following are addressed:

- The risk to the structural integrity of the transmission line.
- The effects on the ability of the transmission line owner to operate, maintain and upgrade the transmission network.
- The risk of electrical hazards affecting public or individual safety, and risk of property damage.
- The extent of earthworks required, and use of mobile machinery near the transmission line which may put the line at risk.
- Minimising the visual effects of the transmission line.
- The outcome of any consultation with the affected utility operator.

Restriction on notification

Subject to sections 95A(2)(b), 95A(2)(c), 95A(4) and 95C of the Act, a resource consent application under this rule will be precluded from public notification under section 95A, and limited notification will be served on Transpower New Zealand Limited as the only affected party under section 95B.

19.23

Subdivision and land use activities which do not comply with the access standards in 19.8

Policy 16.4.6

Council will restrict its discretion to, and may impose conditions on:

- The extent to which the activity will adversely affect traffic and pedestrian safety.
- The extent to which the activity will adversely affect the efficient functioning of the roading network.

For subdivision, Council's discretion is also restricted to the matters listed in rule 19.6.

19.24

Family flats which do not comply with the permitted activity standards

Policy 15.4.1

Council will restrict its discretion to, and may impose conditions on:

- Land tenure.
- Location.
- Provision of and effects on utilities and/or services
- Landscaping
- Setbacks and coverage.
- Height and sunlight access.

- Standard, construction and layout of vehicular access.
- Effects on character and amenity
- Financial contributions

19.25

Home occupations incidental to residential activities carried out on the site which do not meet permitted activity standards

*Policies 5.4.11,
15.4.1*

Council will restrict its discretion to, and may impose conditions on:

- External storage.
- The number of non-resident workers employed on the site.
- The creation of dust, light, noise, vibration or other nuisance.
- Appearance of buildings.
- Size, number of, location and appearance of signs.
- Car parking, traffic and pedestrian safety and the efficient functioning of the roading network.
- Financial contributions.

19.26

Buildings accessory to a permitted or controlled activity which do not meet permitted or controlled activity standards

*Policies 5.4.12,
15.4.1,*

Council will restrict its discretion to, and may impose conditions on:

- Height and sunlight access.
- Setbacks and coverage.
- Landscaping and screening.
- Provision of and effects on utilities and/or services.
- Standard, construction and layout of vehicular access, manoeuvring and traffic safety.
- Streetscape effects.
- Effects on rural character and amenity.
- Financial contributions.

19.27

Signs which do not meet the standards for permitted activities

*Policies 15.4.5,
16.4.4*

Council will restrict its discretion to:

- Whether the sign is in scale with the associated activities or building development and compatible with the visual character

of the area in which it is situated.

- Whether signs are obtrusively visible from any residential area or public space.
- Whether signs will have adverse effects on traffic or pedestrian safety.
- Whether signs detract from the appearance of the building to which they are attached.
- Whether signs will result in additional clutter.

Council may impose conditions on:

- The area of signs.
- The number of signs.
- The colour and materials used.
- The location of signs.
- Sign content.
- Illumination, lighting, reflectorisation and animation.

19.28

Subdivision of a site within the Pinehaven Catchment Overlay

Policy 9.4.10

Standards:

- Achieves hydraulic neutrality.
- Provision of a report by a suitably qualified and experienced person providing an assessment of the ability for the site to achieve hydraulic neutrality in accordance with the requirements of 2.6.9E.
- Compliance with the standards of Rule 19.5.

Council will restrict its discretion to, and may impose conditions on:

- The matters contained in Rule 19.6.
- Ability for the subdivision and proposed design to ensure peak flow of stormwater discharge will be no greater than pre-subdivision levels and thus achieve hydraulic neutrality.
- The effect of the subdivision on the Pinehaven Flood Hazard Extent.
- Recommendations and mitigation measures of the hydraulic report.
- Consent notice restricting the future development of the lot to the design and recommendations of the hydraulic neutrality report.
- Matters addressing the standards for access under Rule 19.8 where any standards are not met.

19.29

Subdivision within the Ponding Area or Erosion Hazard Area of the Mangaroa Flood Hazard Extent which results in any undeveloped lots that contain no dwelling or non-residential building.

Policies 9.4.4, 9.4.5, 14.4.6

Standards:

- where the proposed building platform is located within the Erosion Hazard Area, provision of a report by a suitability qualified and experienced person to determine the erosion risk is required in accordance with 2.6.9D;
- suitable future building platform area for the dwelling must be identified and must not be located within an overflow path or river corridor.
- Access serving the building platform is above the 1 in 100-year flood level and does not cross an overflow path or river corridor.
- Complies with the standards of Rule 19.5.

Council will restrict its discretion to, and may impose conditions on:

- The matters contained in Rule 19.6.
- The appropriateness of the proposed building platform in terms of area and location in relation to the flood hazard and/or erosion risk;
- Ability for a future dwelling to be constructed above the 1 in 100 year flood level.
- The effect of the future development of the building platform on the function of the floodplain.
- Consent notice restricting the future development to the identified platform.
- The suitability of the proposed access to the future building platform to facilitate access during a 1 in 100-year flood event and does not obstruct or divert floodwater flows within the Flood Hazard Extent.

Matters for Consideration

- 19.30** Matters that may be relevant in the consideration of any Discretionary or Non-Complying Activity resource consent may include the following:

Subdivision

- The requirements of section 106 of the Act.
- Whether the proposed allotments are capable of accommodating a range of activities in compliance with zone standards.
- Whether the subdivision compromises future subdivision potential of the land.
- The cumulative effect on existing infrastructure as a result of the proposed subdivision.
- The extent of compliance with Council's Code of Practice for Civil Engineering Works.
- Where located within the Mangaroa Flood Hazard Extent:
 - An assessment of the proposed access to the building platform to achieve suitable access during a 1 in 100-year flood event, and its effect on obstructing or diverting overflow paths or floodwater flows within the Flood Hazard Extent.
 - ability for the building platform to accommodate a future building with a finished floor level above the 1 in 100-year level
 - suitability of the proposed lot areas to accommodate future activities
 - Consent notice restricting the future development to the identified building platform area.

Access

- Accessibility for public transport, cyclists and pedestrians.
- Compliance with the Code of Practice for Civil Engineering Works.
- Whether the topography, size or shape of the site or the location of any natural or built feature(s) on the site or other requirements such as easements, rights-of-way or restrictive covenants impose constraints that make compliance impracticable.
- Whether the activities proposed will not generate a demand for servicing facilities.
- Whether suitable alternative provision for servicing can be made.
- Whether the nature of adjacent roads is such that the entry, exit and manoeuvring of vehicles can be conducted safely.

Intensive animal farming, including pig farming
<ul style="list-style-type: none"> • Whether amenities of the surrounding environment can be maintained. • Whether the effluent from the site can be discharged appropriately.
Forestry
<ul style="list-style-type: none"> • The method and timing of the activity. • The area to be cleared at any one time. • Traffic and access considerations and financial contributions regarding these. • Effects on the amenity of neighbouring residential properties.
Topsoil removal
<ul style="list-style-type: none"> • Whether the activity is to be the subject of a Management Plan to provide certainty as to the nature, timing and duration of ongoing activity, and a Rehabilitation Plan to show how the land will be restored to a state that respects the natural landform and ensures its long term sustainability for plant growth. • The nature and extent of effects on visual amenity or on sites or features of ecological, cultural or heritage value. • The nature and extent of effects on water bodies, including effects on water quality and the potential for flooding. • The extent to which the activity causes or exacerbates soil erosion or compromises the versatility of the soil resource. • Whether the activity includes measures to deal with the effects of wind blown soil and dust. • The effects of vehicle movements to, from and within the site. • Regard for the provisions of the Regional Soil Plan (including Appendix 3 'Guidelines for Topsoil Mining'). • The nature and effectiveness of measures to avoid, remedy or mitigate adverse effects. • Noise. • Financial contributions.
Active recreation
<ul style="list-style-type: none"> • The location, hours of operation and layout of facilities in relation to their noise effects on adjoining land uses. • Access and parking. • Timing and frequency of events.
Non-rural activities
<ul style="list-style-type: none"> • Whether the activity, buildings, structures or other works are of an appropriate scale having regard to the local landforms and the nature of the surrounding environment. • Whether the amenities and the quality of the rural environment can be maintained. • The potential impacts of noise, dust, glare, vibration, fumes, smoke, discharges or pollutants or the excavation or deposition of earth. • Traffic effects and access to formed, sealed roads. • Whether the site of any non-rural or residential use is appropriately located having regard to the scale of the building development proposed and the intensity of the activity. The Council will consider the extent to which any non-rural activity, building, dwelling or structure may hinder the continued operation of any lawfully established activity. • The extent to which landscape character and ecological values will be maintained or enhanced.

Dwellings
<ul style="list-style-type: none"> • Provision for effluent treatment, disposal and water supply. • The necessity for the number of dwellings proposed. • Whether the form, scale and character of the new buildings are compatible with those of the buildings in the immediate vicinity of the site.
Scale, bulk, location and appearance of buildings
<ul style="list-style-type: none"> • Whether the building design, appearance, location and scale detrimentally affects the character of the surrounding area. • Whether a better standard of development can be achieved by varying the design, location or size of the buildings. • The arrangement of buildings, car parks and vehicle movements on site. • Whether the topography of the site has been taken into account.
Amenity values
<ul style="list-style-type: none"> • Whether the proposed activity will have more than minor effect on the amenity values of the area in which it is to be located.
Sunlight access
<ul style="list-style-type: none"> • Whether the building will adversely interfere with sunlight access or create adverse shading on surrounding sites. • Whether the topography of the site or the location of any built features on the site or other requirements, such as easements, impose constraints that make compliance impracticable.
Signs
<ul style="list-style-type: none"> • Whether the sign is in scale with the associated activities or building development and compatible with the visual character of the area in which it is situated. • Whether signs are obtrusively visible from any residential area or public space. • Whether signs will have adverse effects on traffic or pedestrian safety. • Whether signs detract from the appearance of the building to which they are attached. • Whether signs will result in additional clutter.